

SPECIFIED TO THE OPENING

Ceiling mount — manual & motorized.

Bracket fixes to blocking above the ceiling line; roll sits below the soffit. The assembly is identical in both drives; the operating mechanism and drop clearance change. Use the clearances to design the recess.

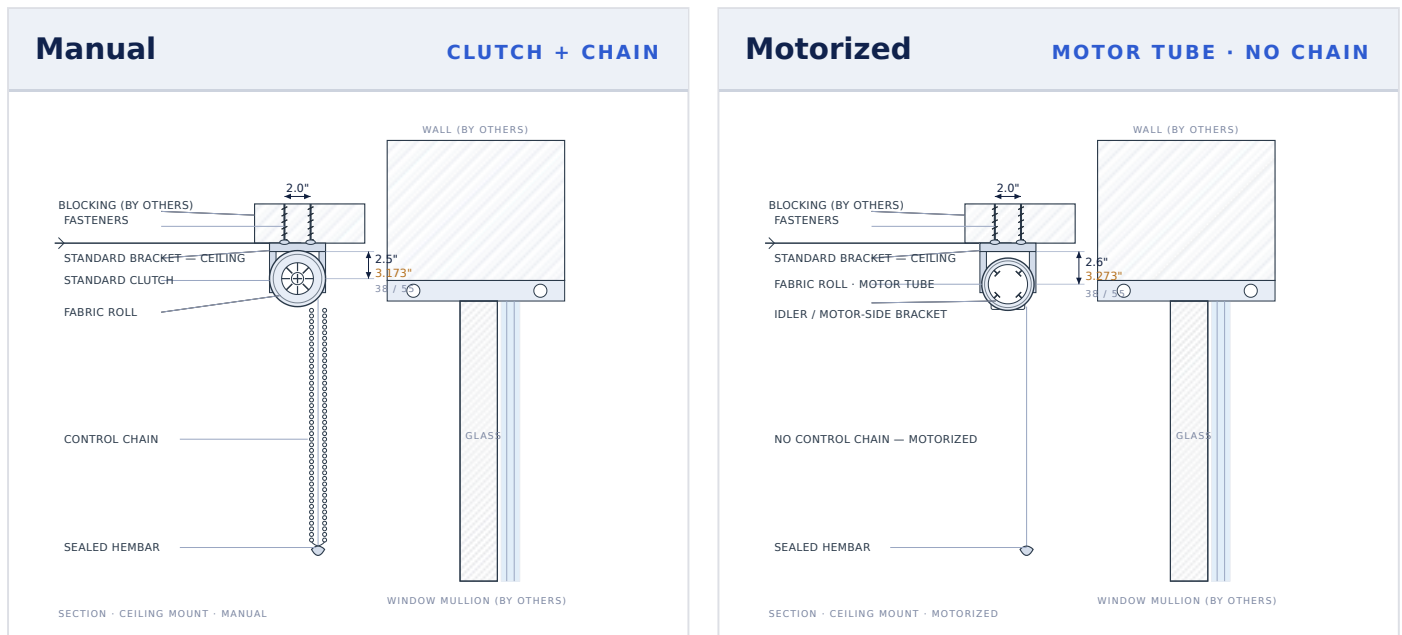

COMMON TO BOTH		MANUAL		MOTORIZED	
Fixing	To blocking (by others)	Operation	Clutch + chain	Operation	Motor tube · no chain
Projection	2.0"	Drop · 38	2.5"	Drop · 38	2.6"
Hembar	Sealed	Drop · 55	3.173"	Drop · 55	3.273"

Dimensions are nominal clearances for design coordination, confirmed with SUNX per project. 55 mm clearance derived from the confirmed 38→55 tube offset (+0.673"); 55 mm fasteners offset 1.94" at the ceiling condition. Components shown generically: standard bracket, standard clutch, fabric roll, sealed hembar. Items marked "by others" are supplied and installed by the relevant trade.

SPECIFIED TO THE OPENING

Face mount — manual & motorized.

Bracket fixes to the face of the mullion; fasteners horizontal. The assembly is identical in both drives; the operating mechanism and drop clearance change. Use the clearances to design the recess.

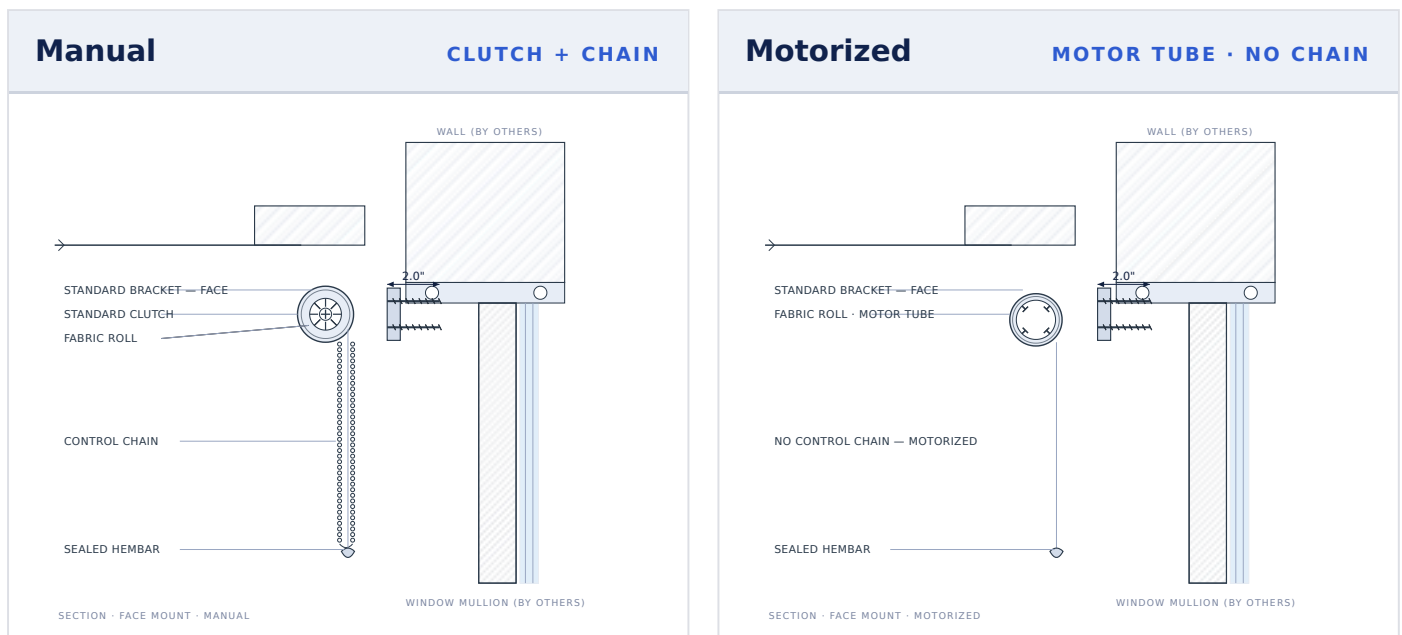

COMMON TO BOTH		MANUAL		MOTORIZED
Fixing	To mullion face (by others)	Operation	Clutch + chain	Operation
Projection	2.0"	Drop · 38	2.5"	Motor tube · no chain
Hembar	Sealed	Drop · 55	3.173"	Drop · 38
				Drop · 55
				3.273"

Dimensions are nominal clearances for design coordination, confirmed with SUNX per project. 55 mm clearance derived from the confirmed 38→55 tube offset (+0.673"); 55 mm fasteners offset 1.94" at the ceiling condition. Components shown generically: standard bracket, standard clutch, fabric roll, sealed hembar. Items marked "by others" are supplied and installed by the relevant trade.

SPECIFIED TO THE OPENING

Wall mount — manual & motorized.

Bracket fixes back to the wall; roll stands off the wall face. The assembly is identical in both drives; the operating mechanism and drop clearance change. Use the clearances to design the recess.

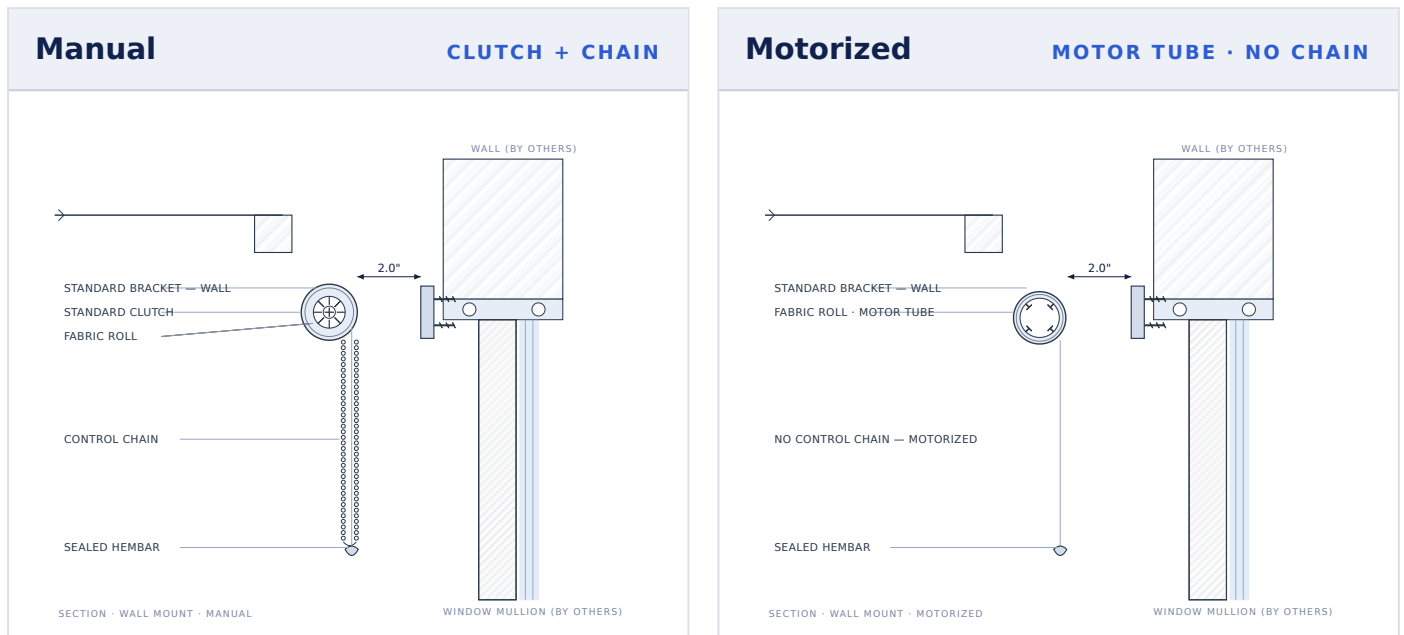

COMMON TO BOTH		MANUAL		MOTORIZED	
Fixing	To wall / blocking (by others)	Operation	Clutch + chain	Operation	Motor tube · no chain
Projection	2.0"	Drop · 38	2.5"	Drop · 38	2.6"
Hembar	Sealed	Drop · 55	3.173"	Drop · 55	3.273"

Dimensions are nominal clearances for design coordination, confirmed with SUNX per project. 55 mm clearance derived from the confirmed 38→55 tube offset (+0.673"); 55 mm fasteners offset 1.94" at the ceiling condition. Components shown generically: standard bracket, standard clutch, fabric roll, sealed hembar. Items marked "by others" are supplied and installed by the relevant trade.

SPECIFIED TO THE OPENING

Inside mount — manual & motorized.

Bracket fixes up inside the opening reveal; system sits within the head. The assembly is identical in both drives; the operating mechanism and drop clearance change. Use the clearances to design the recess.

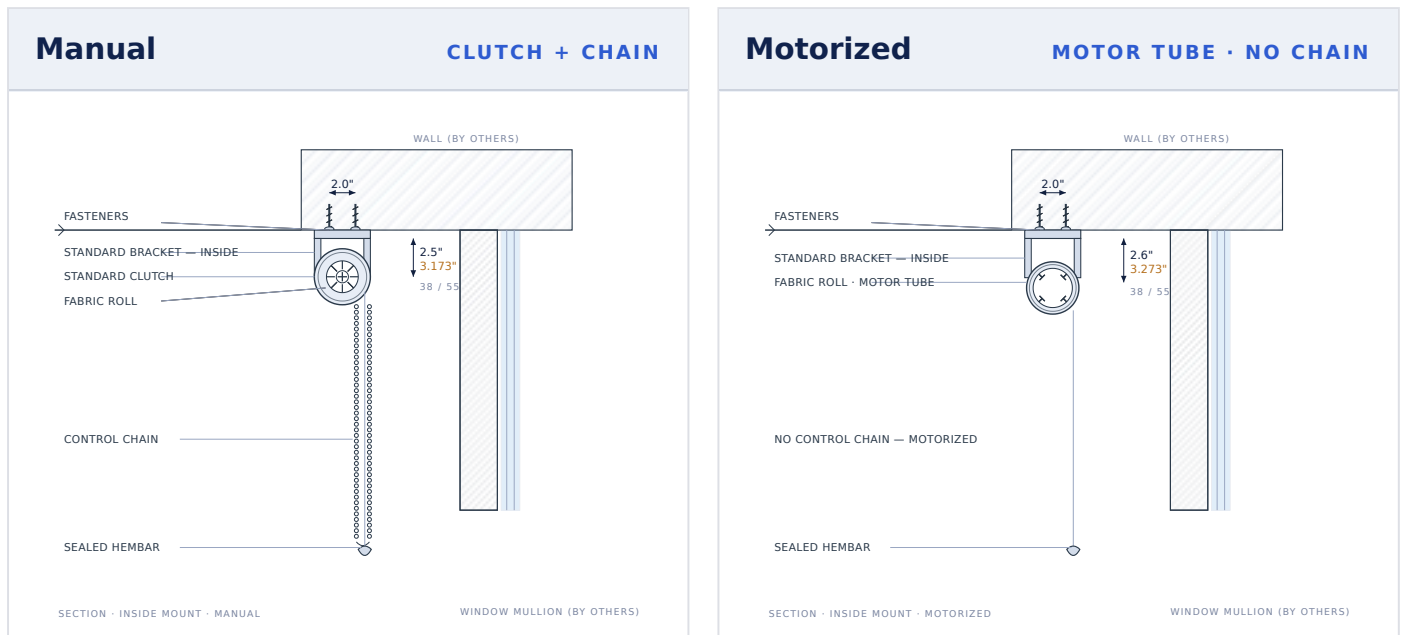

COMMON TO BOTH		MANUAL		MOTORIZED	
Fixing	To head of opening (by others)	Operation	Clutch + chain	Operation	Motor tube · no chain
Projection	2.0"	Drop · 38	2.5"	Drop · 38	2.6"
Hembar	Sealed	Drop · 55	3.173"	Drop · 55	3.273"

Dimensions are nominal clearances for design coordination, confirmed with SUNX per project. 55 mm clearance derived from the confirmed 38→55 tube offset (+0.673"); 55 mm fasteners offset 1.94" at the ceiling condition. Components shown generically: standard bracket, standard clutch, fabric roll, sealed hembar. Items marked "by others" are supplied and installed by the relevant trade.

SPECIFIED TO THE OPENING

Surface pocket — manual & motorized.

Roll concealed in an aluminium surface pocket with bottom closure. The assembly is identical in both drives; the operating mechanism and drop clearance change. Use the clearances to design the recess.

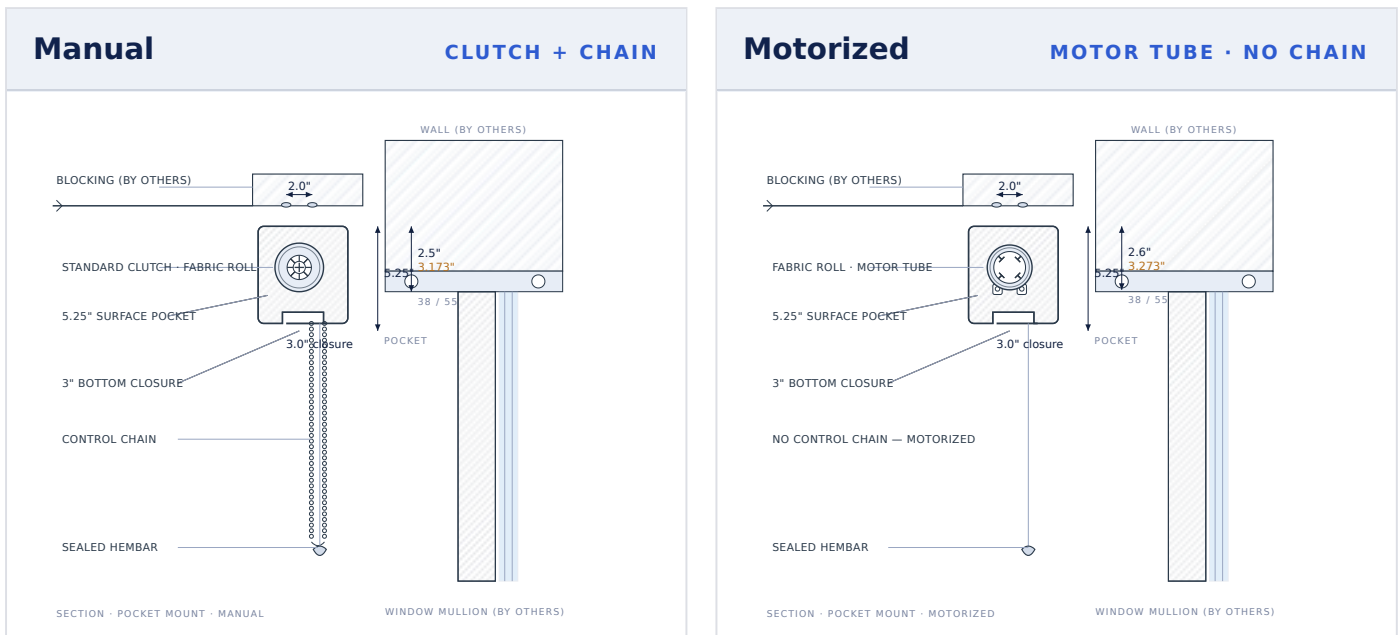

COMMON TO BOTH		MANUAL		MOTORIZED
Fixing	Pocket to blocking (by others)	Operation	Clutch + chain	Operation
	2.0"	Drop · 38	2.5"	Motor tube · no chain
Projection	2.0"	Drop · 55	3.173"	Drop · 38
Hembar	Sealed			Drop · 55
				3.273"

Dimensions are nominal clearances for design coordination, confirmed with SUNX per project. 55 mm clearance derived from the confirmed 38→55 tube offset (+0.673"); 55 mm fasteners offset 1.94" at the ceiling condition. Components shown generically: standard bracket, standard clutch, fabric roll, sealed hembar. Items marked "by others" are supplied and installed by the relevant trade.